

**P3-63/I4**  
**P3-63/I4/SVB**  
**P3-100/I5**  
**P3-100/I5/SVB**

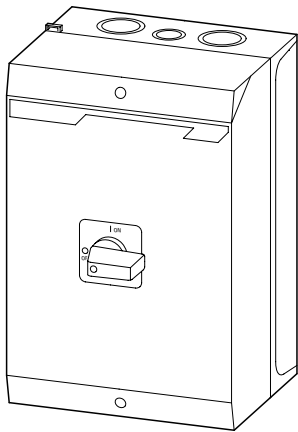

P3...63/I4  
 P3...100/I5

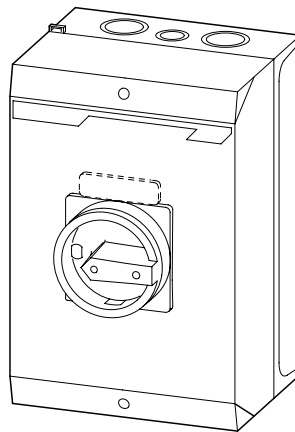

P3...63/I4/SVB  
 P3...100/I5/SVB



**Lebensgefahr durch elektrischen Strom!**  
 Nur Elektrofachkräfte und elektrotechnisch unterwiesene Personen dürfen die im Folgenden beschriebenen Arbeiten ausführen.

**Electric current! Danger to life!**

Only skilled or instructed persons may carry out the following operations.

**Tension électrique dangereuse !**

Seules les personnes qualifiées et averties doivent exécuter les travaux ci-après.

**Tensione elettrica: Pericolo di morte!**

Solo persone abilitate e qualificate possono eseguire le operazioni di seguito riportate.

**Prąd elektryczny! Zagrożenie życia!**

Poniższe czynności mogą być wykonywane tylko przez przeszkolony personel.



**Электрический ток! Опасно для жизни!**

Только специалисты или проинструктированные лица могут выполнять следующие операции.

**触电危险!**



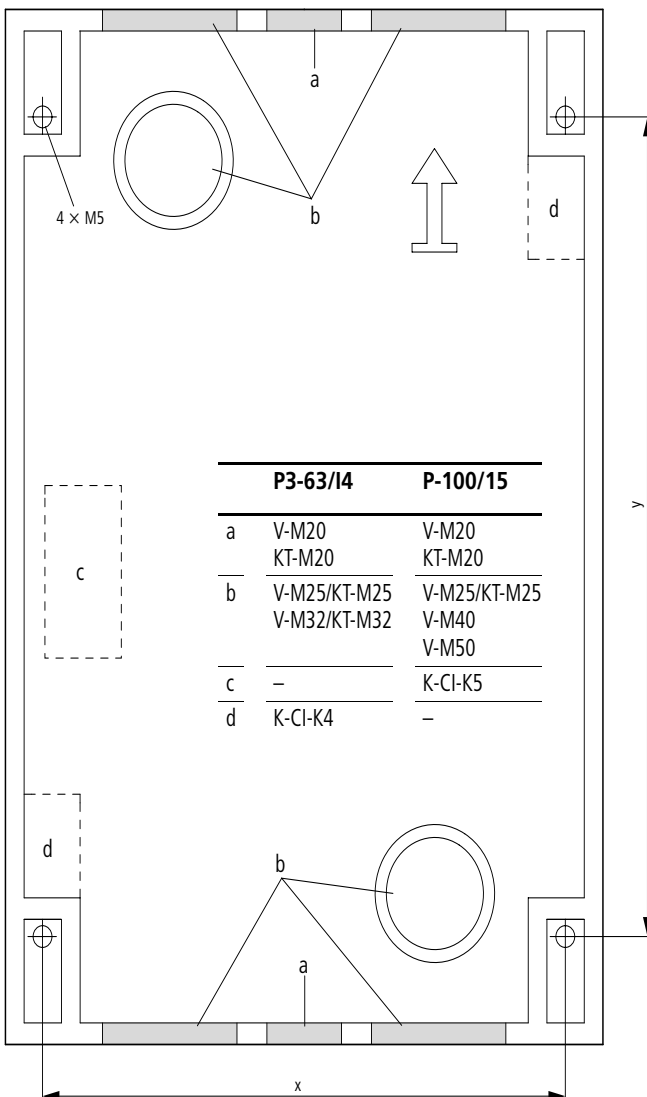

只允许专业人员和受过专业训练的人员进行下列工作。

**HI11-P1/P3**

	0.5 – 1.5 mm <sup>2</sup>	0.6 Nm
	0.75 – 2.5 mm <sup>2</sup>	0.6 Nm



**P3...**

	1 × 1.5 – 25 mm <sup>2</sup>	3 Nm
	2 × 1.5 – 6 mm <sup>2</sup>	
	1 × 2.5 – 35 mm <sup>2</sup>	3 Nm
	2 × 2.5 – 10 mm <sup>2</sup>	

UL-File: E36 332

UL AWG 14/2 3 Nm

Moment dokręcania 26.5 cala-lbs (3 Nm)

75 ° tylko Cu

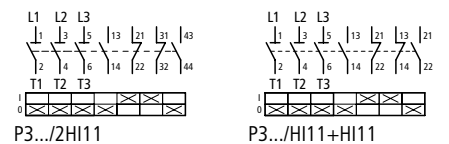
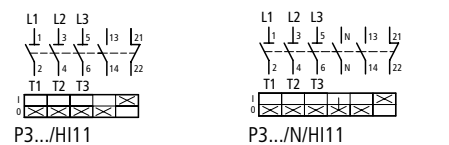
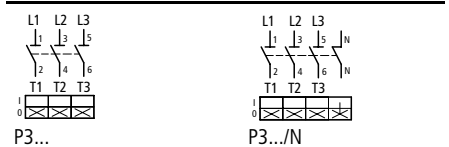

**P3-63/I4 P3-100/I5**

x	142	182
y	193	233

**P3-100/I5(-RT)**  
**P3-100/I5/SVB(-SW)**

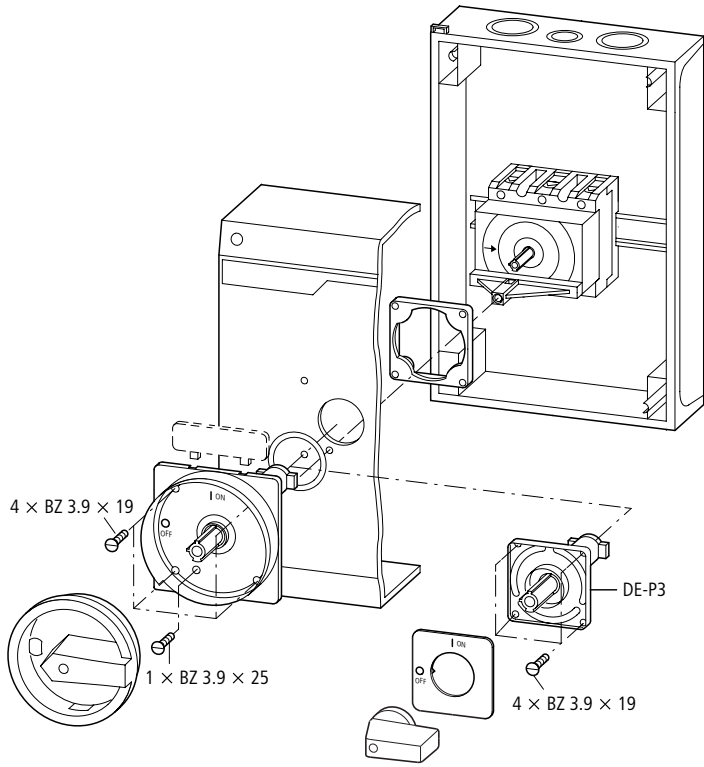

**P3-63/I4(-RT)**  
**P3-63/I4/SVB(-SW)**

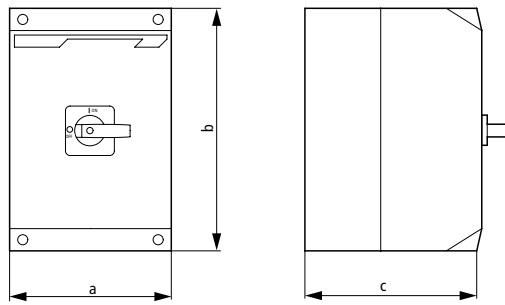
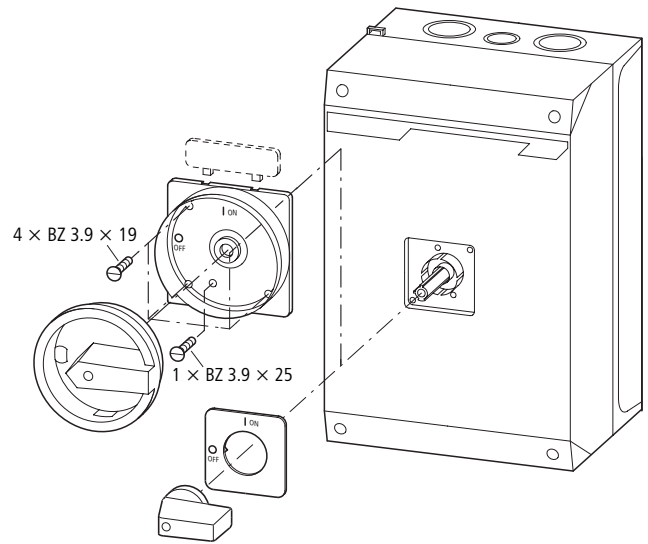

	P3-63/I4	P3-100/I5
a	160	200
b	240	280
c	95	125

**SVB-SW-P3**

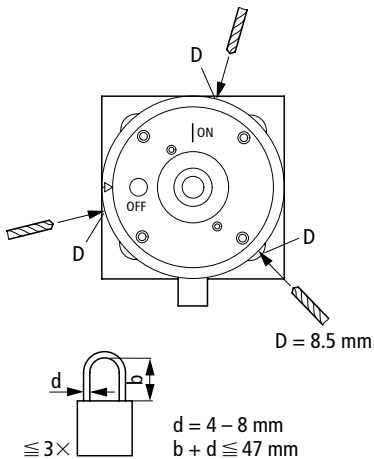

Nur SVB-SW: In ON-Position abschließbar  
**Warnung!**  
 Abschließen in ON-Position bei rot-gelbem Schalter verboten!

Only SVB-SW: Lockable in ON position  
**Warning!**  
 Locking the red-yellow switch in ON position is forbidden!

SVB-SW uniquement: cadenassable en position ON (fermé)  
**Attention !**  
 Cadenassage en position ON (fermé) interdit avec un appareil rouge-jaune !

Solo per SVB-SW: lucchettabile nella posizione ON  
**Attenzione!**  
 È vietato lucchettare nella posizione ON l'interruttore con maniglia rosso-giallo!

Tylko SVB-SW: Blokowane w pozycji ON  
**Uwaga!**  
 Blokowanie czerwono-żółtego łącznika w pozycji ON jest zabronione!

Только SVB-SW: Запираемый в позиции «ON»  
**Предупреждение!**  
 При красно-желтом выключателе запрещается запирасть в позиции «ON»!

只有黑白的SVB可在接通的状态下锁闭。

**警告!**

当红黄色的开关在接通的状态时禁止锁闭。

Gestrichelt gezeichnete Komponenten gehören nicht zum Lieferumfang.

Components drawn in broken lines are not included in the scope of delivery.

Les éléments représentés en pointillés ne font pas partie de la fourniture.

Gli apparecchi contrassegnati con un tratteggio con fanno parte della fornitura.

Elementy narysowane przerywanymi liniami nie wchodzą w zakres dostawy.

Заштрихованные компоненты не входят в объем поставки.

当红黄色的开关在接通的状态时禁止锁闭。

08/06 AWA1150-1982